



Meijer Holland

bale handling systems

Jumbo AA 5

Manual
Bale grab



Content

1. Introduction	4
2. Technical specifications.....	5
3. Safety precautions.....	6
4. The functioning of the bale grab	7
5. Installation, starting up, adjustment	8
6. Operation and use.....	9
7. Maintenance.....	10
8. Problems and solutions	11
9. Environment and disposal	12
10. Assembly drawings.....	13
CE-Declaration of conformity.....	14

1. Introduction

The bale grab Jumbo AA 5 is designed to be attached to a telescopic handler, front loader, wheel loader or crane (hereinafter referred to as 'vehicle') in order to grab and transport wrapped bales over a short distance. The bale grab is equipped with a hydraulic circuit that is to be connected to the hydraulic system of the vehicle to which the bale grab is mounted.



It is important to read the manual carefully before using the machine. Should this not be the case, there can be the risk of serious injury or death for the user and damages to the environment. Moreover, there is the risk of damage to the materials or to the machine. Therefore it is essential that you follow the instructions of this manual.

2. Technical specifications

Features		Jumbo AA 5
height	cm	75
width	cm	235
weight	kg	200
volume hydraulic circuit	ltr	5
max. number of bales		5
bale dimensions (lxwxh)	cm	85x50x40
max. pressure hydraulic circuit	bar	180



When using a vehicle with a pressure higher than 180 bar, it is strongly recommended to use a pressure relief valve. This is available at Meijer Holland.

CE-marking

This machine is certified with the CE-marking. This means that the machine meets the requirements of the applicable EC directives on safety and health. These directives are specified in the attached declaration of conformity.



- The non-observance of the rules and instructions stated in this manual is to be considered as serious negligence which leads to the extinguishment of any liability on the part of Meijer Holland concerning the resulting consequences. In this case, the risk lies exclusively with the user.
- Meijer Holland is constantly busy with the improvement of its products. Therefore it also reserves the right to make any changes that are considered necessary. There is no obligation to apply these changes to earlier delivered machines.

3. Safety precautions

The following precautions are important to prevent injuries and damages.

1. Read the manual before use.
2. Only experts should (dis)mount the bale grab to the vehicle.
3. Only experts should operate the bale grab.
4. Use the bale grab only for bales.
5. Check whether the hydraulic system is working well right after having mounted the bale grab.
6. Follow the instructions for use (chapter 6).
7. The working area of the machine is five meters:
 - no persons are allowed within that range!
8. Operate the bale grab exclusively from the cabin of the vehicle.
9. Mind the rules for max. load (chapter 2).
10. Be aware of oil leakage:
 - check the hydraulic hoses and cylinders at least once per day.
11. Replace damaged or worn wires and cylinders immediately.
12. Follow the instructions for maintenance (chapter 7).
13. Take into account that the sight of the driver is limited when there are bales in the bale grab.
14. When driving longer distances or driving on a public road:
 - no bales are permitted in the bale grab!
15. When reversing:
 - make sure that there are no people behind the vehicle



Build the stack of straw and hay bales in a stable way so that it cannot fall over. The driver must be aware of the rules that apply to the lifting and hoisting of heavy loads.

4. The functioning of the bale grab

Mount the bale grab to a vehicle with a hydraulic system. The bale grab only works when it is attached correctly to the hydraulic system of the vehicle.

- The wrapped bales are clamped with five clamping arms, of which four clamping arms are driven by hydraulic device. This movement can be seen in the figures below.
- The first bale is picked up without a device. Four running wheels operate the hydraulic devices so that each subsequent bale can be clamped separately using one hydraulic valve on your machine.
- First two bales in the transverse direction and then three bales in the longitudinal direction to complete the pattern.
- All the bales are released at once.



movement clamping arms

5. Installation, starting up, adjustment



Check if the bale grab is undamaged and in good condition on delivery. Please contact Meijer Holland if you notice any damages. Use the grab only if it is found to be in good order and after this manual has been read.

5.1 After delivery

- Place the bale grab on a solid and even ground.

5.2 Before moving the bales

1. Assemble the mounting parts.
2. Drive the vehicle in such a way to the bale grab that the mounting surface of the vehicle falls against the mounting point of the bale grab.
3. Attach the bale grab to the vehicle.
4. Check the couplings for dirt. Attach only clean couplings to prevent dirt from entering the system.
5. Connect the two correct hydraulic hoses of the vehicle to the two quick release couplings above the mounting point of the bale grab. The upper hose is for clamping the bales and the lower one is for releasing them.
6. Check for oil leakage.
7. Check the correct control of the cylinder from the hydraulic system.
8. Put the hydraulic system under pressure and test the bale grab by opening and closing the hooks.

5.3 After moving the bales

1. Place the bale grab with the vehicle on a solid and even ground.
2. Check whether the bale grab stands steady.
3. Disconnect the hydraulic hoses and check them for leakage.
4. Dismount the junction of the vehicle from the bale grab and drive away in reverse.



Store the bale grab in a clean and dry environment until the next use.

6. Operation and use

1. Drive the vehicle to the first bale so that it is positioned in transverse direction under the clamp without the hydraulic device and lower the grab.
2. When the frame pushes against the bale, the hydraulic system can be operated.
3. Once the bales are clamped, put the hydraulic system back in neutral.
4. Lift the bale and drive the vehicle to the place of destination or to the next bale.
5. Drive to the next bale. This one will be positioned in the transverse direction again.
6. Hold the bale grab in such a way that the wheel will be pushed up. By doing so, the hydraulic system will be put under pressure and the clamp arms will close.
7. The third bale will be positioned in the longitudinal direction as well as the fourth and fifth bale.
8. Let the five bales sink to the loading floor and put the hydraulic system in 'return'. By doing so, the five clamp arms retract so that the bales are released at the same time. Lift the bale grab up.
9. The vehicle can now be driven away from the bales in reverse.
10. The bale grab is ready to grab and move another series of bales.

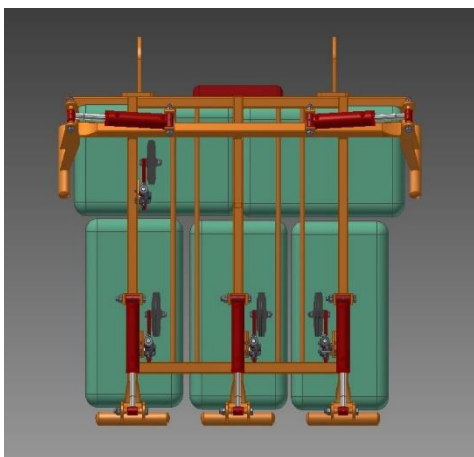
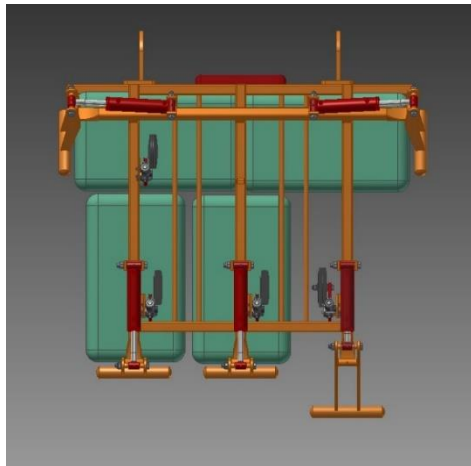
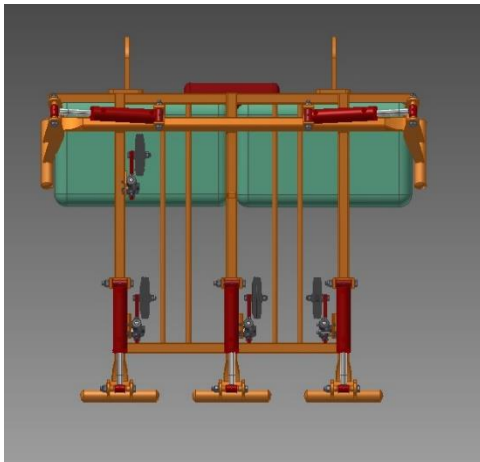

use Jumbo AA 5

7. Maintenance

Regular maintenance extends the life span. The bale grab needs relatively few maintenance.

Maintenance schedule

Before every use	Check the bale collector for damages and wear. Replace damaged or worn parts.
	Check the hydraulic clutch, hoses and cylinders for leakage, wear and damages. Let problems be fixed immediately by a competent mechanic.
At least once a week	Clean the bale grab of caked dirt and dust. When using a high pressure washer, avoid the electrical parts.
	Put grease on the grease nipples. At extensive use: after every eight working hours add a bit of grease (0,86 gram per grease nipple).
	Check the clamp arms for damages in order to prevent damages on the wrapped bales.

8. Problems and solutions

The bale grab has relatively few moveable parts and damages are unlikely to occur when used properly. Repair or replace damaged and worn parts immediately. Spare parts are available at Meijer Holland.



- Turn off the engine of the vehicle while you are fixing one of the below-mentioned problems.
- Turn off the power supply during welding.
- Hydraulic fluid is a poisonous liquid that is harmful to the environment. Never try to shut a leak with your hand. Fluid under high pressure easily penetrates through skin and clothing and can cause serious injuries.

Problem	Possible cause	Solution
The clamp arms do not move.	The hydraulic circuit of the bale grab is not attached to the hydraulic system of the vehicle.	Attach the two hoses.
	The hydraulic circuit of the bale grab is not attached correctly.	Exchange the wrongly attached hydraulic hoses.
	Malfunction in the hydraulic system of the vehicle.	Consult the manual of the vehicle.
	The clamp arm or cylinders are blocked	Look for the blockade and remove it.

9. Environment and disposal

The bale grab has a hydraulic circuit that contains hydraulic fluid, a poisonous liquid that is harmful to the environment. Regularly check the bale grab for leakage and replace damaged or worn parts immediately.

9.1 Disposal of the bale grab

- Drain the hydraulic system and let the fluid be disposed by an authorised company.
- The rest of the bale grab is made of coated steel and can be disposed of as waste.

10. Assembly drawings

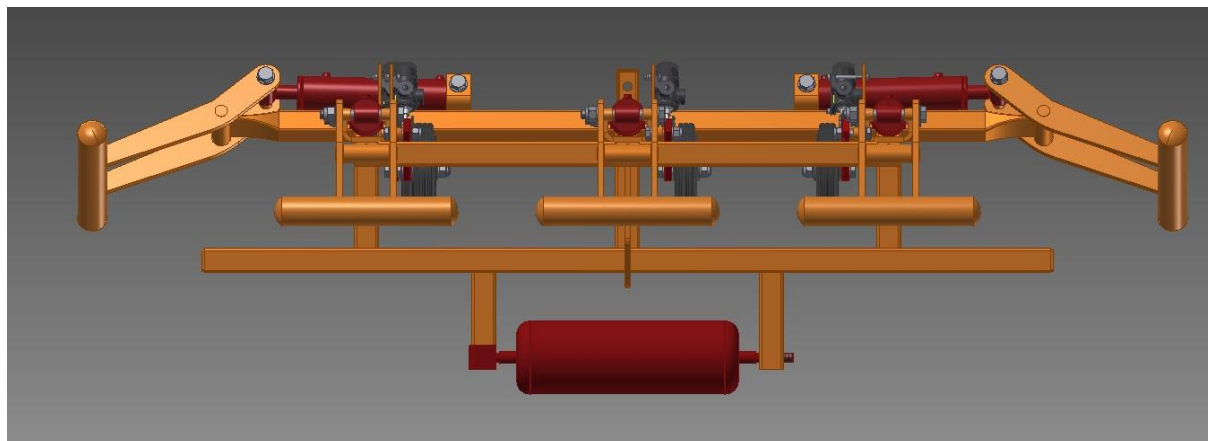

front view Jumbo AA 5

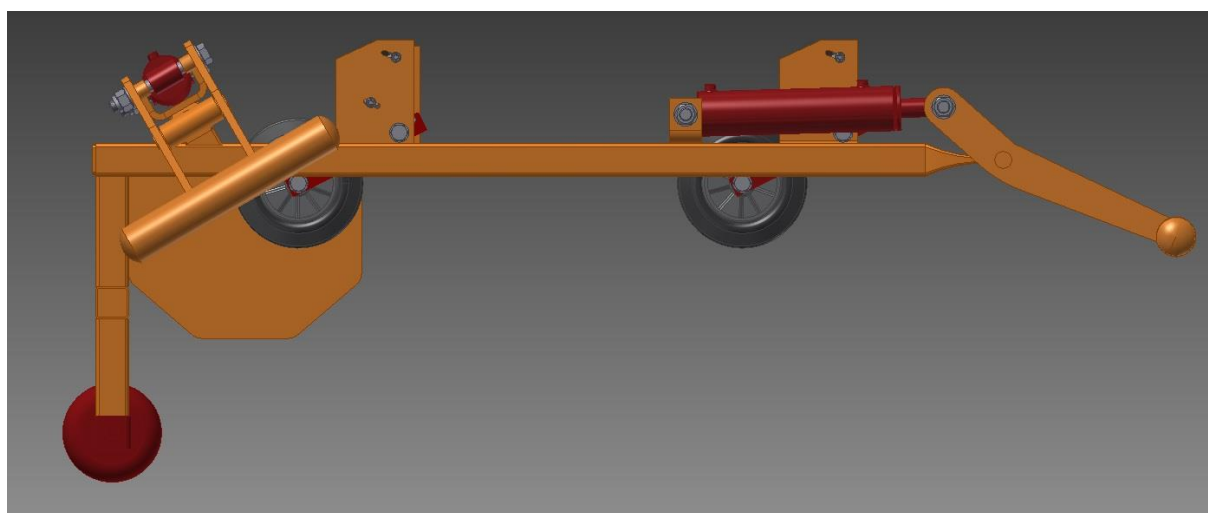

side view Jumbo AA 5

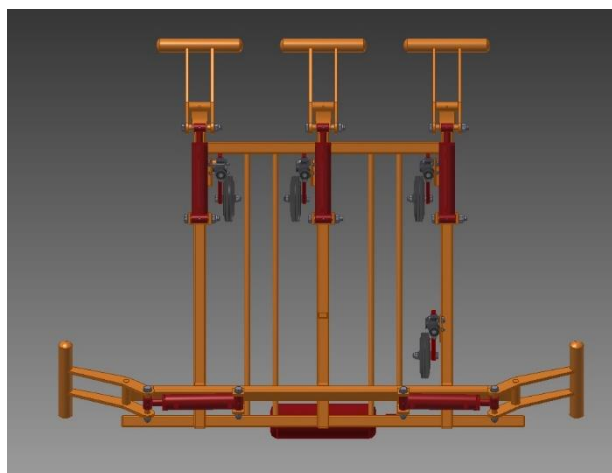

top view Jumbo AA 5

CE-Declaration of conformity

We, Meijer Holland
Bale handling systems
Duinkerkenstraat 11
NL-9723 BN GRONINGEN
Nederland
Tel: +31 (0)50 - 312 64 48

declare under our sole responsibility that:

- 1. we are the manufacturer of:**
MH Jumbo AA 5 (model MHAA05)
- 2. the machine complies with the following applicable directives:**
Machinery directive 2006/42/EG
- 3. the machine is designed and constructed according to European standards, including:**
NEN-EN-ISO 13854:2019
EN-ISO 4413:2010
EN-ISO 12100:2010

The electrics and the control section are the responsibility of the customer.

Groningen, 10 July 2023

J.F. Lommerts, *director*