



Meijer Holland

bale handling systems

Rambo 6K, 6KD, 7K

Manual
Bale grab



Content

1. Introduction	4
2. Technical specifications.....	5
3. Safety precautions.....	6
4. The functioning of the bale grab	7
5. Installation, starting up, adjustment	10
6. Operation and use.....	11
7. Maintenance.....	12
8. Problems and solutions	13
9. Environment and disposal	14
10. Assembly drawings.....	15
CE-Declaration of conformity.....	17

1. Introduction

These Meijer Holland bale grabs of the 'Rambo' type have a folding frame and are designed to be attached to a wheel loader in order to grab and transport straw or hay bales over a short distance. The bale grab is equipped with a hydraulic circuit that is to be connected to the hydraulic system of the wheel loader.



It is important to read the manual carefully before using the machine. There could be a risk of serious injury or damage to the environment if the bale grab is not used properly. Moreover, damages to the material or to the machine might occur. It is therefore important to follow the instructions of this manual.

2. Technical specifications

Features		Rambo 6K	Rambo 6KD	Rambo 7K
height	cm	165	165	165
height folded	cm	300	300	320
width	cm	690	690	785
width folded	cm	300	300	300
weight	kg	1.935	1.950	2.600
volume hydraulic circuit	litres	10-12	10-12	10-12
max. weight bale	kg	500	500	500
Max number of bales (l _w xh) 240x120x90-100 cm		6	6	7
max. pressure hydraulic circuit	bar	180	180	180



The folding Rambo grabs do not work optimally on slopes and very uneven terrain.



When using a wheel loader with a pressure higher than 180 bar, it is strongly recommended to use a pressure relief valve. This is available at Meijer Holland.

CE-marking

This machine is certified with the CE-marking. This means that the machine meets the requirements of the applicable EC directives on safety and health. These directives are specified in the attached declaration of conformity.



- The non-observance of the rules and instructions stated in this manual is to be considered as serious negligence which leads to the extinguishment of any liability on the part of Meijer Holland concerning the resulting consequences. In this case, the risk lies exclusively with the user.
- Meijer Holland is constantly busy with the improvement of its products. Therefore it also reserves the right to make any changes that are considered necessary. There is no obligation to apply these changes to earlier delivered machines.

3. Safety precautions

The following precautions are important to prevent injuries and damages.

1. Read the manual before use.
2. Only experts should (dis)mount the bale grab.
3. Only experts should operate the bale grab.
4. Use the grab only for bales.
5. Check whether the hydraulic system is working well right after having mounted the bale grab.
6. Follow the instructions for use (chapter 6).
7. The working area of the machine is five meters:
 - no persons are allowed within that range!
8. Operate the bale grab exclusively from the cabin of the wheel loader.
9. Mind the rules for max. load (chapter 2).
10. Be aware of oil leakage:
 - Check the hydraulic hoses and cylinders at least once per day.
11. Replace damaged or worn wires and cylinders immediately.
12. Follow the instructions for maintenance (chapter 7).
13. Take into account that the sight of the driver is limited when there are bales in the bale grab.
14. When driving longer distances or driving on a public road:
 - no bales are permitted in the bale grab!
 - fold frame!
15. When reversing:
 - Make sure that there are no people behind the wheel loader.



Build the stack of straw and hay bales in a stable way so that it cannot fall over. The driver must be aware of the rules that apply to the lifting and hoisting of heavy loads.

4. The functioning of the bale grab

Mount the bale grab to a wheel loader with a hydraulic system. The bale grab only works when it is attached correctly to the hydraulic system of the wheel loader.

- The clamping of the bales takes place with the help of hooks that are powered by hydraulic cylinders. This movement can be seen in the figures below.
- The Rambo K has its own clamp for each bale to be picked up.
 - each clamp arm consists of four hooks and one cylinder
 - one clamp arm does not have a hydraulic device; this one grabs the first bale
 - the other clamp arms do have a hydraulic device
- The bales can be grabbed separately as well as simultaneously.

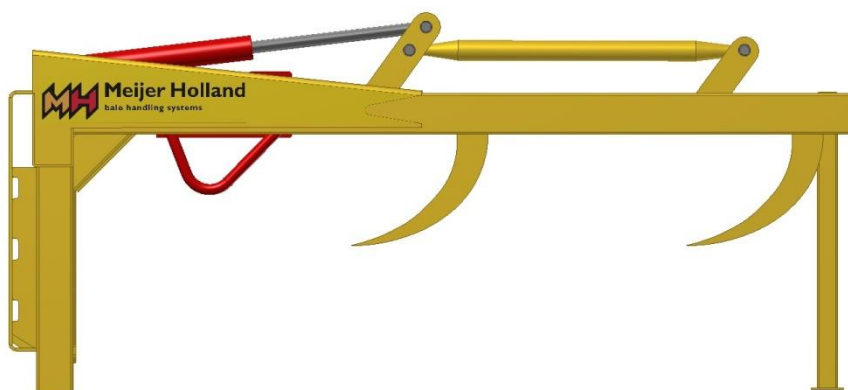
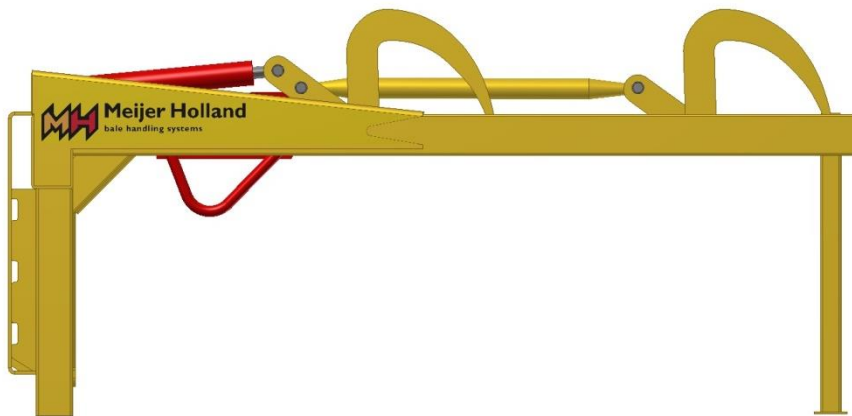

movement clamping hooks (except Rambo 6KD)

Folding and unfolding the bale grab takes places with hydraulically powered cylinders.
(see images below).

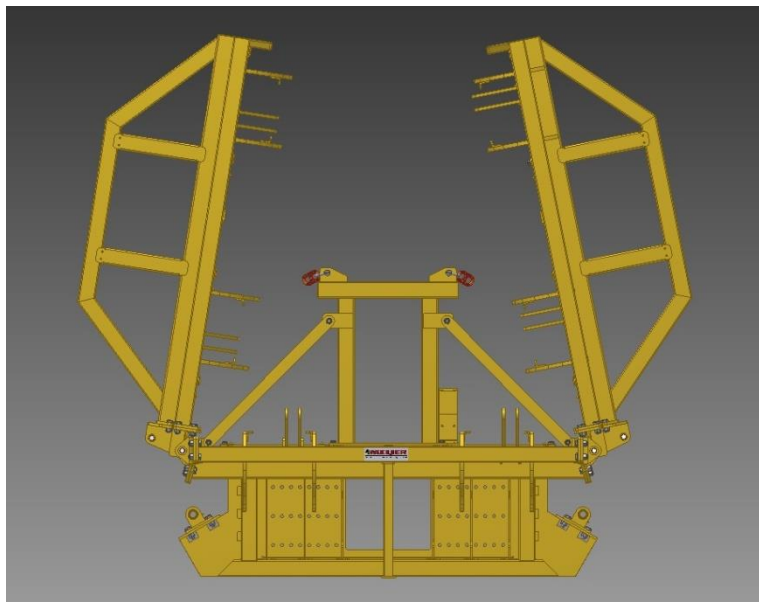

Rambo 6K folded

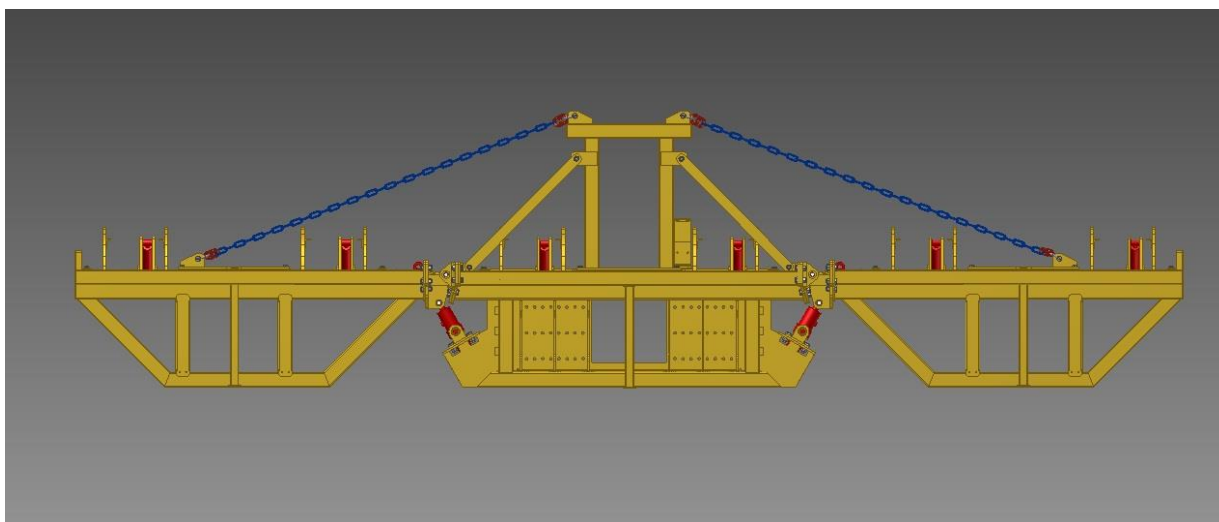

Rambo 6K unfolded

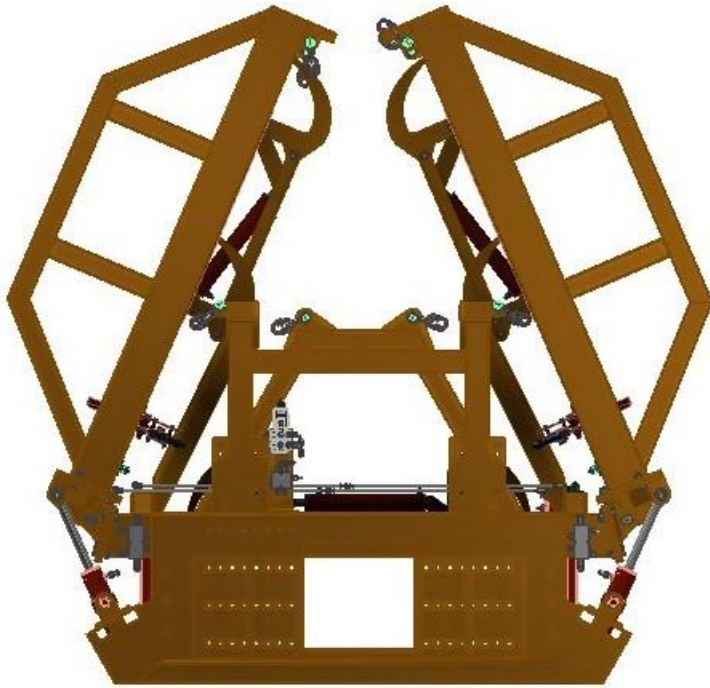

Rambo 6KD folded

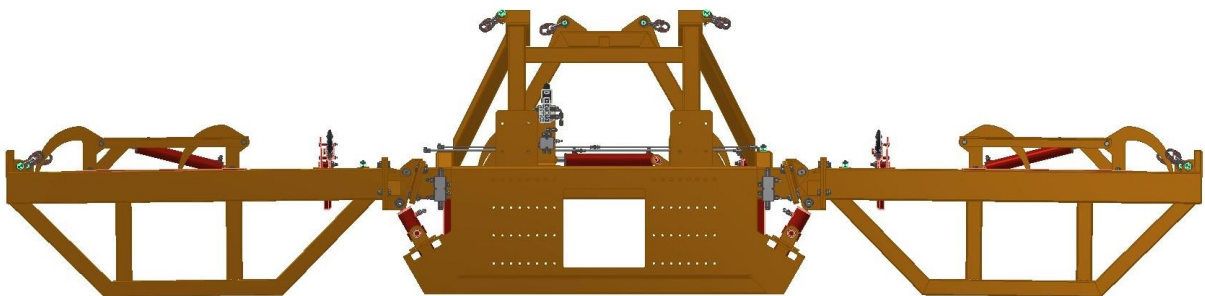

Rambo 6KD unfolded

5. Installation, starting up, adjustment



Check if the bale grab is undamaged and in good condition on delivery. Please contact Meijer Holland if you notice any damages. Use the bale grab only if it is found to be in good order and after this manual has been read.

5.1 After delivery

Place the bale grab on a solid and even ground.

5.2 Before moving the bales

1. Assemble the mounting parts.
2. Drive the wheel loader in such a way to the bale grab that the mounting surface falls against the mounting point of the bale grab.
3. Attach the bale grab to the wheel loader.
4. Check the couplings for dirt. Attach only clean couplings to prevent dirt from entering the system.
5. Connect the two correct hydraulic hoses of the wheel loader to the two quick release couplings above the mounting point of the bale grab. The upper hose is for clamping the bales and the lower one is for releasing them.
6. Check for leakage.
7. Check the correct control of the cylinder from the hydraulic system.
8. Put the hydraulic system under pressure and test the bale grab by opening and closing the hooks.

5.3 After moving the bales

1. Place the bale grab with the wheel loader on a solid and even ground.
2. Check whether the bale grab stands steady.
3. Disconnect the hydraulic hoses and check them for leakage.
4. Dismount the junction of the wheel loader from the bale grab and drive away in reverse.



Store the bale grab in a dry and clean environment until the next use.

6. Operation and use

1. Drive the wheel loader in such a way to the first bale that the clamp arm without hydraulic device hangs right above the bale.
2. Let the bale grab sink until the frame touches the bale.
3. Clamp the bale by closing the hooks. Put the hydraulic system back in 'neutral' afterwards.
4. Lift the bale and drive to the place of destination or to the next bale.
5. For the following bales: Drive again in such a way to the bale that the still empty clamping hooks hang right above the bale the frame touches the it. Hold the grab in a way that the wheel is pushed upwards. By doing so, the valve opens and the bales will be clamped.
6. Let the bales sink to the loading floor en put the hydraulic system in 'return'. By doing so, the hooks open and the bales are released. Lift the bale grab up.
7. The wheel loader can now be driven away from the bales in reverse.
8. The bale grab is ready to grab and move another series of bales.



use Rambo 6K and 7K

7. Maintenance

Regular maintenance extends the life span. The bale grab needs relatively few maintenance.

Maintenance schedule

Before every use	Check the bale grab for damages and wear. Replace damaged or worn parts.
	Check the hydraulic clutch, hoses and cylinders for leakage, wear and damages. Let problems be fixed immediately by a competent mechanic.
At least once a week	Clean the bale grab of caked dirt and dust. When using a high pressure washer, avoid the electrical parts.
	Put grease on the grease nipples. At extensive use: after every eight working hours add a bit of grease (0,86 grams per grease nipple).

8. Problems and solutions

The bale grab has relatively few moveable parts and hardly any wear occurs when used properly. Repair or replace damaged and worn parts immediately. Spare parts are available at Meijer Holland.



- Turn off the engine of the wheel loader while you are fixing one of the below-mentioned problems.
- Turn off the power supply during welding.
- Hydraulic fluid is a poisonous liquid that is harmful to the environment. Never try to shut a leak with your hand. Fluid under high pressure easily penetrates through skin and clothing and can cause serious injuries.

Problem	Possible cause	Solution
The hooks are not moving.	The hydraulic circuit of the bale grab is not attached to the hydraulic system of the wheel loader.	Attach the two hoses.
	The hydraulic circuit of the bale grab is not attached correctly.	Exchange the wrongly attached hydraulic hoses.
	Malfunction in the hydraulic system of the wheel loader.	Consult the manual of the wheel loader.
	The hooks or the axes on which they are attached are blocked.	Look for the blockade and remove it.

9. Environment and disposal

The bale grab has a hydraulic circuit that contains hydraulic fluid, a poisonous liquid that is harmful to the environment. Regularly check the bale grab for leakage and replace damaged or worn parts immediately.

9.1 Disposal of the bale grab

- Drain the hydraulic system and let the fluid be disposed by an authorised company.
- The rest of the bale grab is made of coated steel and can be disposed of as scrap.

10. Assembly drawings

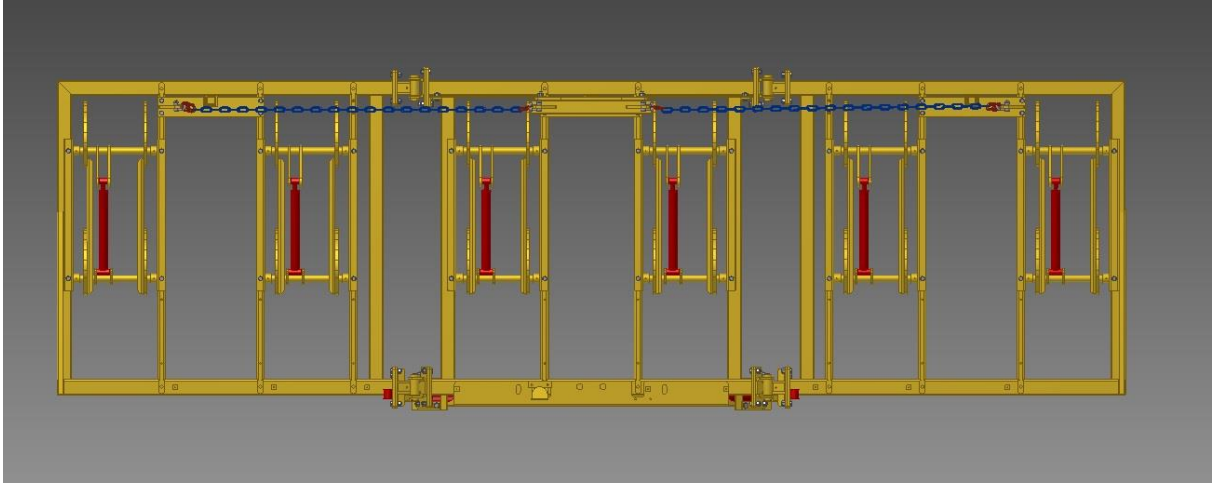

top view Rambo 6K

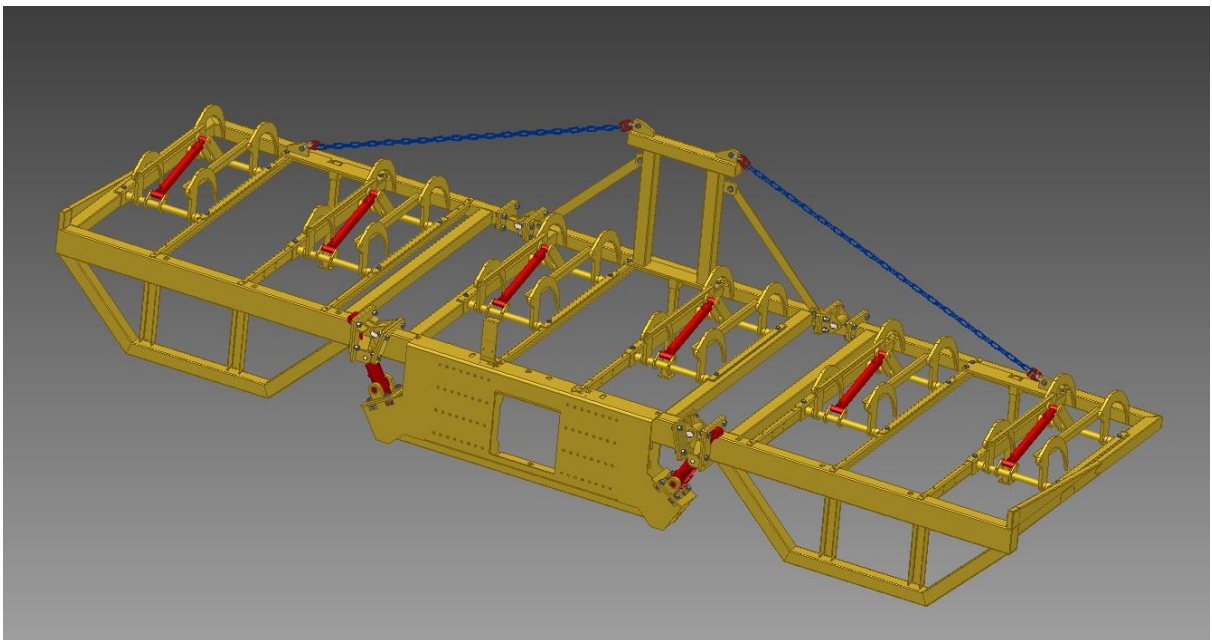

isometric view Rambo 6K

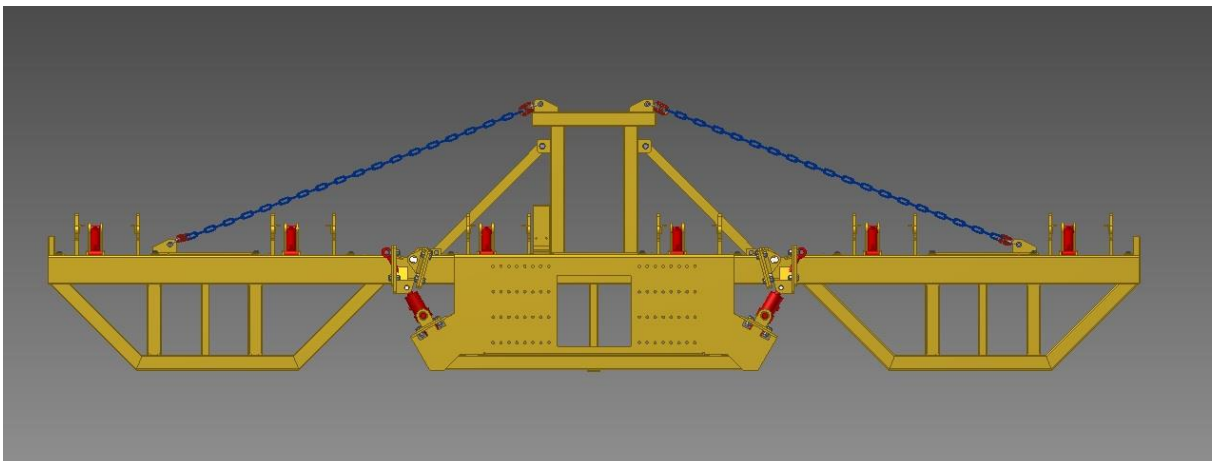

rear view Rambo 6K

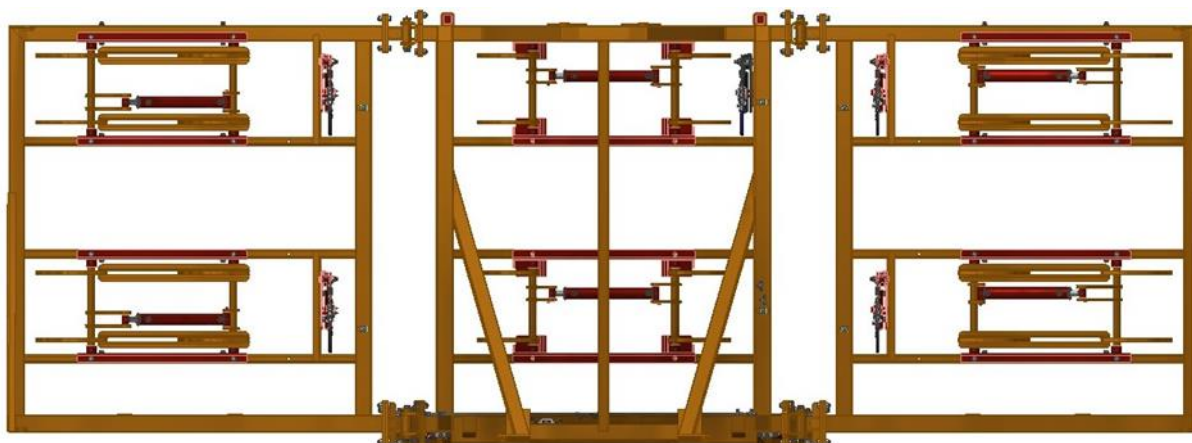

top view Rambo 6KD

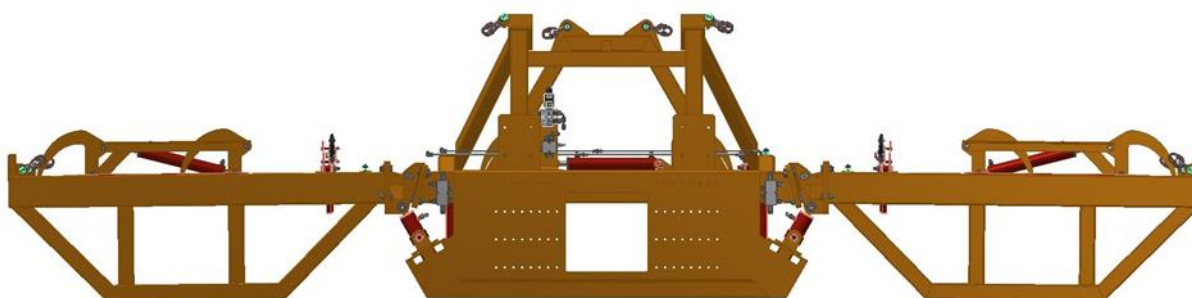

rear view Rambo 6KD

CE-Declaration of conformity

We, Meijer Holland
Bale handling systems
Duinkerkenstraat 11
NL-9723 BN GRONINGEN
The Netherlands
Tel: +31 (0)50 - 312 64 48

declare under our sole responsibility that:

1. we are the manufacturer of:

- MH Rambo 6K (model MHRAMBO06k)
- MH Rambo 6KD (model MHRAMBO06KD)
- MH Rambo 7K (model MHRAMBO07K)

2. the machine complies with the following applicable directives:

- Machinery directive 2006/42/EG

3. the machine is designed and constructed according to European standards, including:

- NEN-EN-ISO 13854:2019
- EN-ISO 4413:2010
- EN-ISO 12100:2010

The electrics and the control section are the responsibility of the customer.

Groningen, 10 July 2023

J.F. Lommerts, *director*